

17	16	15	14	13	12	11	10
18	ZIEL	30	29	28	27	26	9
19	20	21	22	23	24	25	8
START	1	2	3	4	5	6	7

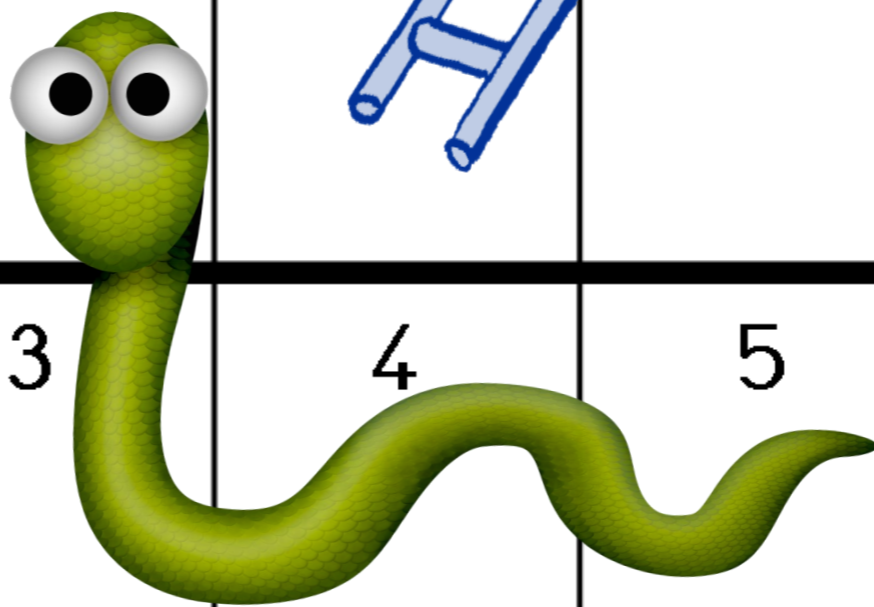

23	22	21	20	19	18	17	16	15	14
24	43	42	41	40	39	38	37	36	13
25	44	45	46	47	48	49	50 ZIEL	35	12
26	27	28	29	30	31	32	33	34	11
1 START	2	3	4	5	6	7	8	9	10

A board game grid with numbers 1-50. The grid is 5 rows by 10 columns. The numbers are arranged as follows: Row 1: 23, 22, 21, 20, 19, 18, 17, 16, 15, 14; Row 2: 24, 43, 42, 41, 40, 39, 38, 37, 36, 13; Row 3: 25, 44, 45, 46, 47, 48, 49, 50 (ZIEL), 35, 12; Row 4: 26, 27, 28, 29, 30, 31, 32, 33, 34, 11; Row 5: 1 (START), 2, 3, 4, 5, 6, 7, 8, 9, 10. A green snake is on each of the numbers 1, 2, 3, 4, 7, 10, 27, 28, 34, 41, 48, and 49. Blue ladders are on 16-17, 24-25, 28-29, 36-37, and 42-43. The cell with 50 is shaded grey and labeled 'ZIEL'.

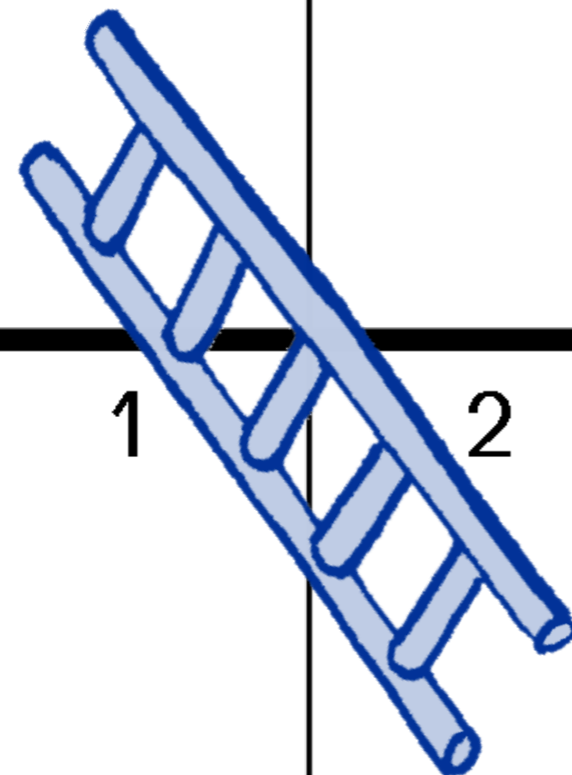
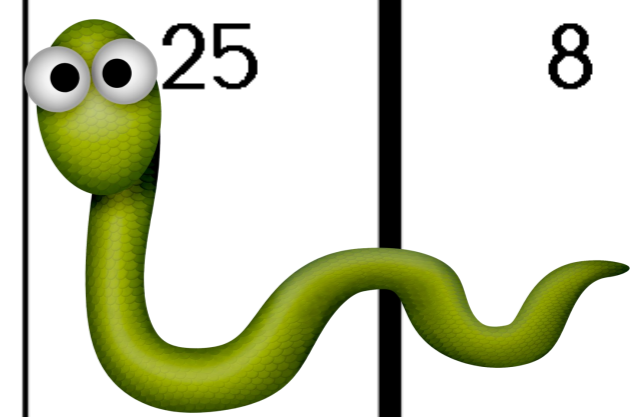
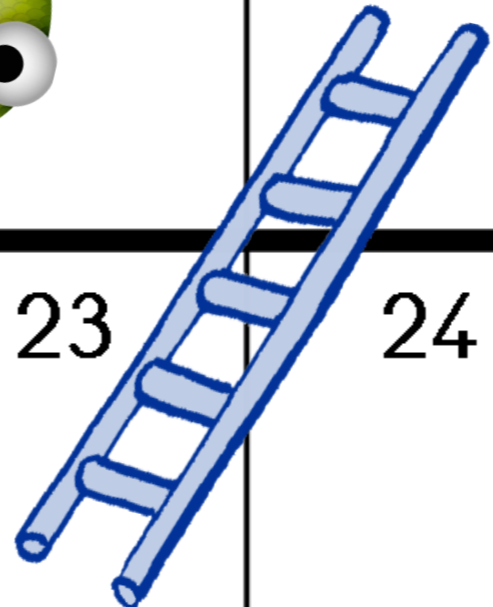
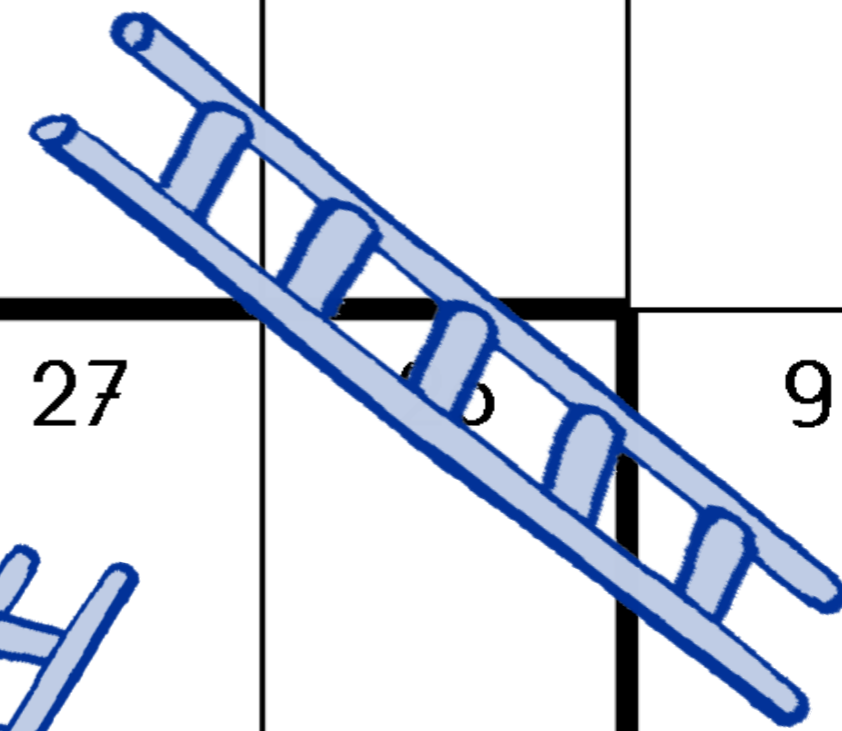
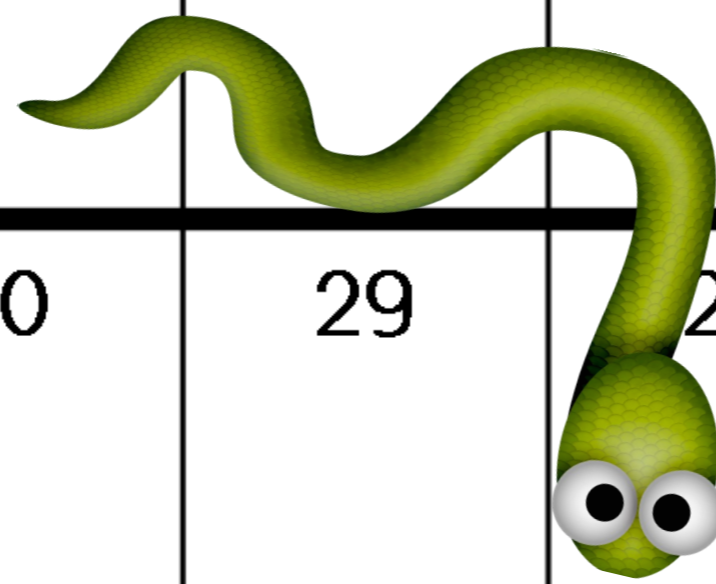